

Gas Mass Flow Meters with Digital Display

Features

- Direct monitoring of mass flow rate eliminates need for ancillary pressure and temperature sensing
- Digital display of mass flow rate on flow body or remote version for panel mounting
- Electronic output of mass flow rate for control or data-logging
- Fast response to changes in flow rate
- Large, straight sensor tube reduces contamination and maintenance down-time
- Platinum sensor eliminates zero drift and ensures long-term repeatability
- Primary standard calibration ensures starting point accuracy and NIST traceability
- CE Approved

TopTrak[®] 822/824



DESCRIPTION

Sierra Instruments' TopTrak[®] 820 Mass Flow Meter is designed to replace volumetric flow rate devices at a comparable installed cost. No temperature or pressure corrections are required, as in the case of most other flow monitoring devices, such as rotometers, turbine meters or critical orifices.

Available in flow ranges from 0 to 10 sccm up to 0 to 50 slpm, TopTrak is suitable for any clean gas flow measurement application. Wetted surfaces are rugged 316 stainless steel, nickel plating, 6/6 reinforced Nylon[®] and Viton[®] "O" rings; all are corrosion-resistant.

The 820 measures and displays the mass flow rate directly in sccm or slpm. The integral instrument display is tiltable over 180° for easy viewing and can be removed for remote panel mounting. A 0 to 5 VDC or 4 to 20 mA output signal linearly proportional to gas mass flow rate is provided for recording, data-logging or control. This device is widely used in a variety of flow validation and calibration applications-by dozens of instrument OEMs and in a multitude of laboratory, test and analytical operations.



www.sierrainstruments.com

The information contained herein is subject to change without notice.

DIMENSIONAL SPECIFICATIONS

Model 820—Side View

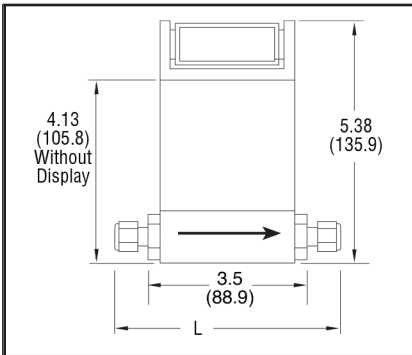

Model 820—Outlet View

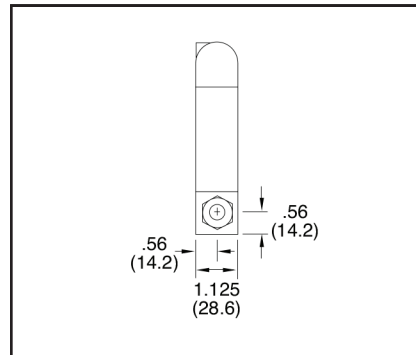

Model 820 —Bottom View

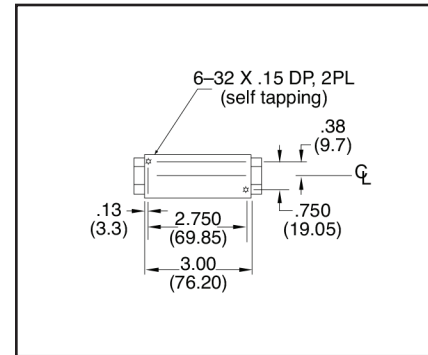

All dimensions are inches and in parentheses are millimeters. Certified drawings are available on request.

FITTING SIZE			
	1/8-inch Compression	1/4-inch Compression	1/4-inch NPT
Dim. L	5.51(140.0)	5.70 (144.8)	3.50 (88.9)

Performance Specifications

Accuracy

+/- 1.5% of Full Scale under calibration conditions including linearity over 15° to 25°C and 5 to 60 psia (0.3 to 4 bara).

If the meter is mounted with a vertical (up or down) flow path the following accuracy de-rating applies:

- Notes: (1) Do not exceed 150 psig.
 (2) Difference between inlet pressure and calibrated pressure. Do not exceed ± 10 psig.

OPERATING PRESSURE			
Inlet Pressure Deviation ²	50 psig	100 psig	150 psig
+/- 1 psig	+/- 1.5% of Full Scale	+/- 1.5% of Full Scale	+/- 1.5% of Full Scale
+/- 5 psig	+/- 3.8% of Full Scale	+/- 4.5% of Full Scale	+/- 5.3% of Full Scale
+/- 10 psig	+/- 6% of Full Scale	+/- 7.5% of Full Scale	+/- 9% of Full Scale

Repeatability

+/- 0.5% of Full Scale

Temperature Coefficient

0.08% of Full Scale per °F (0.15% of Full Scale per °C), or better

Pressure Coefficient

0.01% of Full Scale per psi (0.15% of Full Scale per bar), or better

Response Time

800 ms time constant; six seconds (typical) within

+/- 2% of final value over 25 to 100% of Full Scale

Gases

OPERATING SPECIFICATIONS

Most gases; check compatibility with wetted materials; specify when ordering

Mass Flow Rates

0 to 10 sccm up to 0 to 50 slpm; flow ranges specified are for an equivalent flow of nitrogen at 760 mm Hg and 21°C (70°F); other ranges in other units are available (e.g., scfh or nm³/h)

Gas Pressure

150 psig (10 barg) maximum;
 20 psig (1.4 barg) optimum

Gas & Ambient Temperature

32 to 122°F (0 to 50°C)

Leak Integrity

1 X 10⁻⁴ atm cc/sec of helium maximum

PRESSURE DROP	
Flow Rate	mbar
100 sccm	0.05
1 slpm	0.54
10 slpm	5.40
20 slpm	23
30 slpm	52
40 slpm	88
50 slpm	122

Power Requirements

12 to 15 VDC, 15 VDC nominal, 100 mA maximum
 24 VDC optional

Output Signal

Linear 0 to 5 VDC, 1000 ohms minimum load resistance
 Linear 4 to 20 mA, 500 ohms maximum loop resistance

Display

3.5 digit LCD (0.6 in H); removable for remote mounting

PHYSICAL SPECIFICATIONS

Wetted Materials

10% glass-filled Nylon® 6/6, 316 stainless steel, nickel plating, Viton® "O"-rings standard
 Neoprene® and 4079 Kalrez® "O"-rings optional

ORDERING THE 822/824

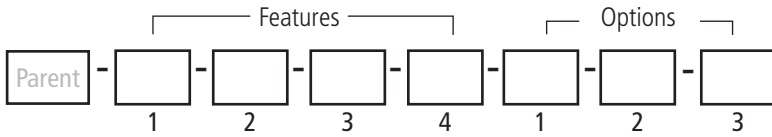

Instructions: To order the 822/824 please fill in each number block by selecting the codes from the corresponding features below and following pages.

Parent Number	
822	TopTrak [®] Mass Flow Meter with Display Flow body constructed of 10.0% glass-filled Nylon 6/6, with Viton [®] "O" rings and 316 stainless steel sensor. 3.5 digit LCD display. Linear, 0-5 VDC output signal; input power 12-15 VDC. Choice of inlet/outlet fittings. 9-pin "D" mating connector. Calibrated for flow ranges from 0-10 sccm to 0-50 slpm equivalent nitrogen flow; +/- 1.5% full scale accuracy; maximum temperature 122°F (50°C); maximum pressure 150 psig (10.3 barg). CE Approved.
824	TopTrak [®] Mass Flow Meter. Same as above with no display.

Note: All slpm flow ranges also available in nlpm
You must select Low Flow Calibration under "Options" for 0-20 sccm full scale flow range or less.

Feature 1 : Fittings	
1	1/8-inch compression for 822, 824 (maximum flow 5 slpm)
2	1/4-inch compression for 822, 824 (maximum flow 50 slpm)
3	3/8-inch compression for 822, 824
5	1/4-inch VCO for 822, 824 (maximum flow 50 slpm)
8	1/4-inch VCR for 822, 824 (maximum flow 50 slpm)
10	6 mm compression for 822, 824 (maximum flow 50 slpm)
11	10 mm compression for 822, 824
13	1/4-inch Female NPT for 822, 824
NX	1/2-inch Female NPT for 826, 827 only

Option 2: Certificates	
CC	Certificate of conformance

Feature 2: Elastomers	
OV1	Viton [®]

Feature 3: Input Power	
PV1	12-15 VDC (see accessories for optional power supply)
PV2	24 VDC (customer must supply 24 VDC power)

Feature 4: Output Signal	
V1	0-5 VDC, linear
V4	4-20 mA, linear

Option 1: Special Cals	
MP	Medium pressure calibration (40-150 psig (2.8-10.3 barg))
LF	Low flow calibration (required for 0-20 sccm full scale flow range or less)

Option 3: Display	
RD()	Remote display. Maximum 100 feet available on models 822 or 826. Specify cable length in parentheses, \$1 per foot. Instruments ordered with remote display are not CE compliant.
T	Totalizer and actual flow in display